

Promat

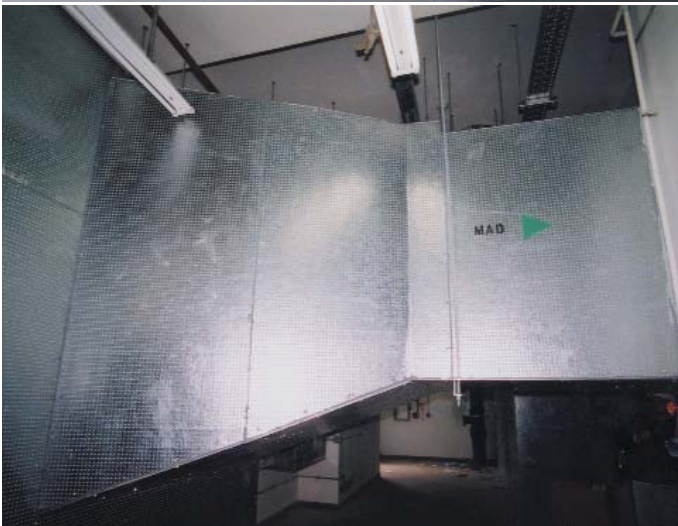

PROMATECT®-S Self-supporting Ducts





Type of self-supporting ducts	System code	FRL	Board thickness	Duct type	Mineral wool	Maximum dimension	Tests and assessments standards/labs	Page no.
	PS 43.12	120/120/-	6mm	A B	Not required	10,000mm x 4000mm	BS476: Part 24 Report no. • BRE CC84362 • BRE CC89275 • LPC CC92293 • LPC CC92294 • BRE CC87622	6
		120/120/60	2 x 6mm	B	Please consult Promat	3000mm x 1500mm		
		120/120/120	2 x 6mm	A B	Please consult Promat	10,000mm x 4000mm		
	PS 43.18	180/180/180	9.5mm	A B	Please consult Promat	3000mm x 1500mm		
	PS 43.24	240/240/-	9.5mm	A B	Not required	10,000mm x 4000mm		
		240/240/120	2 x 9.5mm	A B	Please consult Promat	3000mm x 1500mm		
		240/240/180	2 x 9.5mm	B	Please consult Promat	3000mm x 1500mm		
		240/240/240	9.5mm	A B	Please consult Promat	3000mm x 1500mm		

NOTE: For ducts exposed to external fire (Duct type A) the insulation can be measured inside the duct, inside the fire compartment or outside the duct on an adjacent compartment. All the above provide similar levels of insulation to that listed, when the insulation is measured outside the duct. For details of insulated ducts exposed to external fire where insulation is required inside the duct, or inside the fire compartment, please consult Promat Technical Department.



The relative complexity of any ductwork system which is passing through different fire compartments and the relevance of the system's function in ambient as well as fire conditions can make the selection of a suitable ductwork system difficult.

This section of the handbook aims to give some guidance on the fire performance requirements of ductwork and offers a wide range of solutions for the protection of steel ductwork and for self-supporting systems using PROMATECT®-H, and PROMATECT®-L500.

For particularly onerous conditions, e.g. where high impact strength is required or for use in aggressive environments, Promat have developed a range of systems using the PROMATECT®-S high impact board.

Fire Testing Methods

To determine the fire resistance of ducts (without the aid of fire dampers) passing through or between compartments, the system should normally be tested or assessed in accordance with BS476: Part 24 or AS1530: Part 4. These standards have been written specifically for ventilation ducts, but guidance is also given in these standards on the performance requirements for "smoke outlet" ducts and "kitchen extract" ducts.

Although the following information refers to BS476: Parts 20 to 24, these details apply equally to AS1530: Part 4 in terms of the performance requirements. It should be noted, however, that there are substantial differences between the two standards in terms of testing methodology which greatly affect the results. It is not possible to simply transfer results from AS1530: Part 4 test to BS476: Part 24 due to this huge difference in testing methods.

A part of a standard fire test, duct systems are exposed to external fire (also known as Duct type A) and one sample to both external AND internal fire (also known as Duct type B). Fans create a standard pressure difference and air flow and the ducts fire performance is assessed in both fan-on and fan-off situations. When testing horizontal ducts, a run of at least 3000mm is located within the fire compartment (the EN and revised ISO standards required a 4000mm length exposed) and a further 2500mm outside the fire compartment.

BS476: Part 24 expresses the fire resistance of ducts without the aid of dampers, in terms of stability, integrity and insulation.

Stability failure occurs when the suspension or fixing devices can no longer retain a duct in its intended position or when sections of the duct collapse. This requirement does not apply to the length of the duct exposed to internal fire (Duct type B) within the fire compartment.

It should be noted that if a duct suffers extensive deformation, such that it can no longer fulfil its intended purpose, this would be classed as stability failure. For Duct type A, loss of pressure within the duct during testing is also construed as stability failure.

Integrity failure occurs when cracks, holes or openings occur in the duct or at any penetrations within walls or floors, through which flames or hot gases can pass. The effects on integrity of the movement and distortion of both restrained and unrestrained ducts are also included in the standard.

Insulation failure occurs when the temperature rise on the outer surface of the duct outside the fire compartment exceeds 140°C (mean) or 180°C (maximum). The guidance in the standard also states that ducts lined with combustible materials or coated internally with fats or greases, e.g. kitchen extract, should also have this criterion for the inner surface of the duct within the fire compartment when the duct is exposed to external fire (Duct A).

For smoke extraction, the guidance in the standard states that the cross sectional area of a duct required to extract smoke in the event of a fire should not be reduced by more than 25% for the duration of the fire exposure.

See **Penetration Through Walls & Floors** on opposite page.

General Design Considerations

The following points are some of the factors which should be considered when determining the correct specification to ensure a ductwork system will provide the required fire performance. Further advice can of course be obtained from the Promat Technical Department.

1. Required Fire Exposure

Ductwork systems which are located in more than one compartment should always be tested or assessed for their performance when exposed to the heating conditions described within BS476: Part 20. Reduced heating curves are generally only acceptable for certain of the systems components, e.g. the fan.

The performance of a ductwork system will vary depending on whether or not a fire could have direct access to inside the duct through an unprotected opening. If in doubt, one should assume direct access, i.e. the Duct B scenario described previously under Fire Testing Methods.

2. Required Fire Performance

It is a general requirement that the ducts must satisfy all the relevant performance criteria of stability, integrity and insulation (and cross sectional area if a smoke extraction duct). However, the approval authority may accept relaxations on occasion. For example, if no combustible materials or personnel could be in contact with the duct, the authority may accept a reduced insulation performance.

General Design Considerations

3. Supporting Structure

Care should be taken that any structural element from which the duct system is supported, e.g. a beam, floor or wall, must have as a minimum the same fire resistance as the duct system itself and must be able to support the load of the duct under fire conditions.

4. Hanger Support

The supporting hangers, supports and their fixings should be capable of bearing the load of the complete ductwork system including any applied insulation material or other services suspended from it. Chemical anchors are generally not considered suitable. It is normally not advisable to use unprotected supports if the stress exceeds the values given on [page 5](#) and/or if hanger lengths exceed 2000mm. The hanger centres should not exceed the limits given in [page 5](#).

5. Steel Ductwork

The steel duct must be constructed in accordance with the requirements of DW/144 – Specification for sheet metal ductwork – low, medium and high pressure/velocity air systems (published by the Heating and Ventilating Contractors' Association UK.), or equivalent specification, e.g. SMACNA. The steel ducts must be constructed with rolled steel angle-flanged cross joints. It is recommended that longitudinal seams be formed using the Pittsburgh lock.

6. Penetrations Through Walls & Floors

Care should be taken to ensure that movement of the duct in ambient or in fire conditions does not adversely affect the performance of the wall, partition or floor, or any penetration seal. It should be understood that where a duct passes through any compartment wall or floor or other type of separating element, the aperture between the element and the duct must be sealed in accordance with the system approved for use with the duct. In general this requires the use of a penetration seal constructed from materials and in such a manner to match the system used in the duct test programme. Penetrations seals are part of the tested duct system and the use of untested third party products are not permitted.

7. Movement Joints

Movement joint details may be required for long lengths of duct, particularly where the duct spans across a movement joint in the floor or wall, or passes through floors and roof that may deflect at different rates. Please consult Promat Technical office for details of such joints.

8. Air Flow & Leakage

The design of some fire resisting duct systems may need modification to meet DW/144 performance standards. All Promat self supporting duct systems will meet the requirements of DW/144 to the highest levels, provided the correct board thickness is employed and all joints are correctly sealed in accordance with the system recommendations.

9. Ductwork Functions

Most ductwork systems can fall into one or more of the following categories:

- Ventilation and air conditioning;
- Natural smoke extract;
- Fan assisted smoke extract;
- Pressurisation of escape routes and fire fighting lobbies.

In the event of a fire, the function of a system can often change. For example, an air conditioning system could switch to become a fan assisted smoke extract duct. It is therefore essential that the performance requirements in both normal conditions and fire conditions are considered.

10. Other Requirements

Acoustic performance, thermal insulation, water tolerance, strength and appearance can also be important considerations (See BS8313: 1989 Code of practice for accommodation of building services in ducts).

Selection of Fire Protection System

Traditionally all ductwork was fabricated from steel which normally had to be encased in a fire protection system when passing through a compartment wall or floor without the aid of a fire damper.

In recent years, self-supporting systems without a steel liner have been introduced to extract smoke in the event of a fire through natural ventilation. Now some self-supporting systems, e.g. PROMATECT®-H, PROMATECT®-L500 and PROMATECT®-S are available which can match the leakage and air flow performance of steel ducts in accordance with the DW144 standard up to Class C.

To satisfy the wide range of requirements in the current market, Promat can offer no less than three products to protect steel ductwork and to fabricate self-supporting systems.

For any size of duct, the tensile stress in the steel hangers must not exceed 10N/mm² for fire resistance up to 120 minutes, or 6N/mm² for fire resistance up to 240 minutes. These figures are based on work carried out by Warrington Fire Research Centre (now Bodycote) in the UK and European research projects into the stress and strains of steel members under simulated fire conditions.

The stress reduction ratio factors mentioned below are based on BS5950: Part 1: 1990. Similar figures can be applied from AS4600.

The method to calculate whether the diameter of the threaded rod is within the permitted stress level is given below.

Fire resistance period	Approximate temperature	Maximum permitted stress	Maximum permitted centres
30 minutes	840°C	18/mm ²	2500mm
60 minutes	950°C	10/mm ²	2500mm
90 minutes	1000°C	10/mm ²	2500mm
120 minutes	1050°C	10/mm ²	2500mm
180 minutes	1110°C	6/mm ²	2000mm
240 minutes	1150°C	6/mm ²	1500mm

It should be noted that the stress levels referred to above apply to the threaded rod hanger supports themselves. The horizontal members have a differing level of applicable stress (see [page 5](#)). The maximum centres refers to the greatest allowable distance between hanger support systems. However it should be noted that in certain locations, bends for instance, additional supports at lesser centres should be considered.

Where the hanger support system may exceed the limits given in the table above the remedial options are as follows:

- 1) Increase the dimensions of the hanger support system, e.g. rod diameters etc,
- 2) Reduce the centres of the hanger support system,
- 3) Protect the hanger rods.

Hangers supporting steel ducts protected with Promat materials can be left unprotected providing the maximum stress on each hanger does not exceed the values given in the above table and importantly that their length does not exceed 2000mm. Where hanger rods exceed this dimension, there is a high risk of stability failure of the duct due to excessive expansion of the support system. If hanger rods exceed 2000mm, they should be protected at all times for all systems, regardless of system type or manufacturer.

Stress Calculation For Hangers

To calculate the stress in N/mm² on each hanger, the total weight of the ductwork and fire protection materials being taken by each hanger should be calculated in kilograms, converted to Newtons (N) by multiplying by 9.81 and then divided by the cross-sectional area of the hanger in mm². The cross-sectional area of a circular hanger is $\pi \times r^2$ where r is the radius of the support rod. It should be noted that the root diameter of the threaded rod should be applied in this calculation, not the outer diameter of the thread. Please refer to the table below for details.

The method to calculate whether the diameter of the threaded rod is within the permitted stress level is given below.

Nominal outer diameter	Root diameter	Cross sectional area
6mm	5.06mm	20.10mm ²
8mm	6.83mm	36.63mm ²
10mm	8.60mm	58.08mm ²
12mm	10.36mm	84.29mm ²
14mm	12.25mm	117.85mm ²
16mm	14.14mm	157.03mm ²
18mm	15.90mm	198.55mm ²
20mm	17.67mm	245.20mm ²

The density of steel is approximately 7850kg/m³, therefore the weight of steel (kg) = 7850 x surface area (m) x steel thickness (m).

The following example of calculating the stress of the support system is based on the use of PROMATECT®-H boards, however, this method would apply to all fire resisting systems.

Board thickness (mm)	=	12
Duct height (m)	=	1.0
Duct width (m)	=	1.0
Centres of hangers (m)	=	1.22
Area of boards	=	(Width x 2) + (Height x 2) x Centres of hangers
Weight of boards	=	Area x Thickness x Density (975kg/m ³)
Weight of angles	=	(Centres of hangers x 4) + (Width x 4) + (Height x 4) x 0.63kg/m
Section weight (kg)	=	68.62 (inclusive of angles)
Weight on one hanger	=	34.31
Total force (N)	=	336.58 (Weight (kg) x 9.81 = N)
Diameter of steel rod (mm)	=	8
Cross-section area (mm ²)	=	38.63
Stress (N/mm ²)	=	$\frac{F}{A}$ where F = force in Newton A = area of rod cross section
	=	8.71N/mm ²

Since the stress is less than 10N/mm² as set in the table above, an 8mm diameter rod is the minimum permissible for the duct of cross section 1000mm x 1000mm x 1220mm length constructed with a single layer of 12mm PROMATECT®-H. If cladding a steel duct, the weight of this has to be included within the total weight supported upon the hangers.

If these stress levels are exceeded then the size of the hanger members must be increased, or the centres of the hangers reduced or the hangers protected. The penetration of the hanger fixings into any concrete soffit should be a minimum of 40mm for up to 120 minutes ratings or 60mm for more than 120 and up to 240 minutes ratings.

To calculate the stress of the horizontal supporting angle of channel, the following would apply.

Board thickness (mm)	=	12
Duct height (m)	=	1.0
Duct width (m)	=	1.0
Centres of hangers (m)	=	1.22
Area of boards	=	(Width x 2) + (Height x 2) x Centres of hangers
Weight of boards	=	Area x Thickness x Density (975kg/m ³)
Weight of angles	=	(Centres of hangers x 4) + (Width x 4) + (Height x 4) x 0.63kg/m
Section weight (kg)	=	68.62 (inclusive of angles)
Total force (N)	=	673 (Weight (kg) x 9.81 = N)
Maximum bending Moment, M	=	$\frac{W \times L^2}{8} = 101.79$
Stress, S	=	$\frac{M}{Z} < 19.5$ where Z is the section modulus in cm ³
Section modulus, Z	=	$> \frac{M}{19.5}$
Z	=	$> 4.7\text{cm}^3$

Using C-channels of uniform thickness in web and flanges, the dimensions of channel:

Breadth of channel (cm)	=	3
Depth of channel (cm)	=	5
Thickness of channel (cm)	=	0.4
Section modulus	=	$\frac{B \times D^2}{6} - \frac{b \times d^2}{6}$ = 4.9cm ³

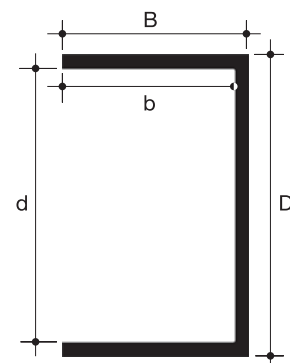

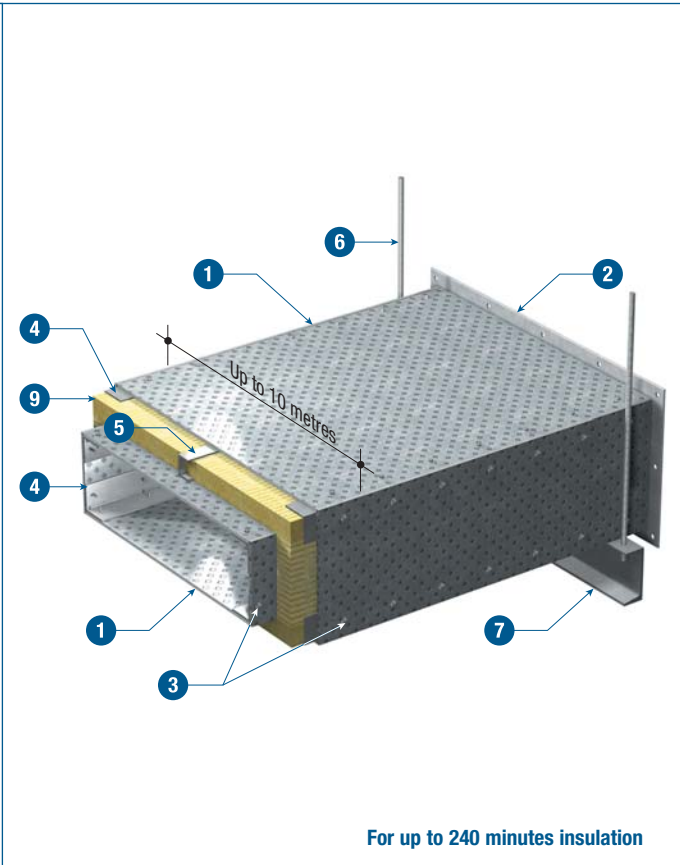
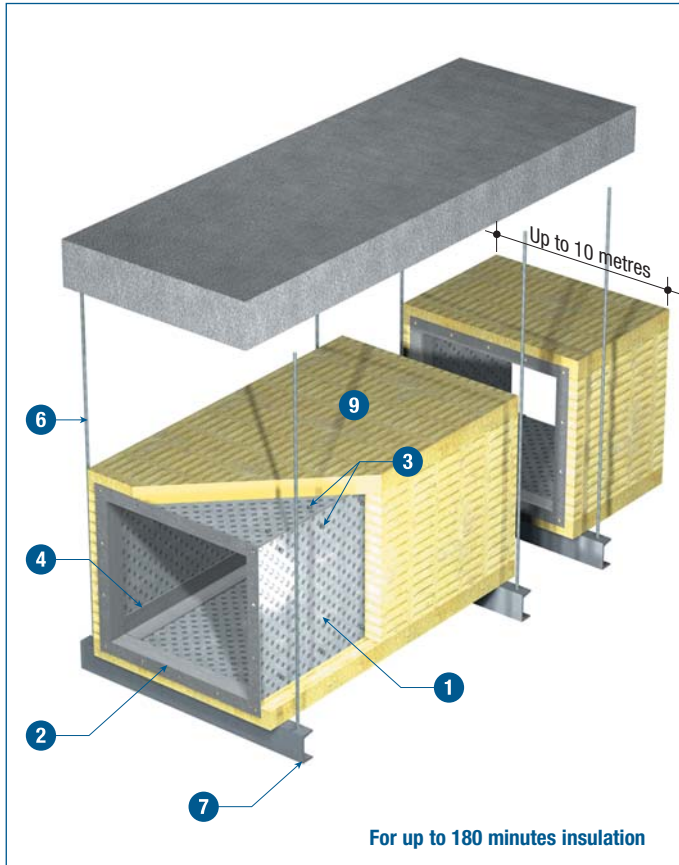

TECHNICAL DATA

- 1 1 or 2 layers of PROMATECT®-S board, see page 2 for details.
For FRL up to 120/120/120 6mm thick
For FRL up to 240/240/240 9.5mm thick
- 2 Steel flanges, fabricated by cutting and welding 50mm x 50mm x 3mm thick angles, are bolted together with M10 nuts and bolts at nominal 200mm centres to form continuous sections.
Alternatively, systems have been tested which utilise standard steel duct flange systems. For further information pertaining to the construction of such systems, please consult Promat Technical Department.
- 3 35mm x 5.5mm Teks screws at nominal 200mm centres
- 4 Steel angles 50mm x 50mm x 3mm thick, these corner reinforcement angles do not require any mechanical fixing to the flanges.
- 5 Steel channels 50mm x 3mm x mineral wool thickness for support of board joints
- 6 Duct hanger system, stress calculation according to page 5.
- 7 Steel angles or channels, size according to calculation of maximum stress depending on the weight and size of the duct.
- 8 Mild steel flat bar 100mm x 3mm thick
- 9 1 layer of mineral wool where required, please consult Promat Technical Department for details.

NOTE: Maximum duct dimensions can differ depending upon FRL. Please consult Promat Technical Department for details pertaining to special maximum permitted width or height.

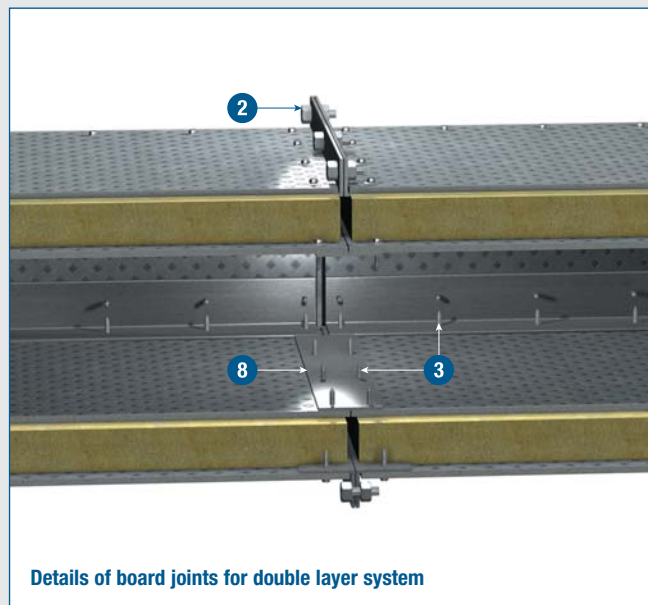

Both single and double layer systems of PROMATECT®-S self-supporting ducts have been tested and approved for the construction of high pressure duct systems in accordance with DW144 Class C.

The above construction of self-supporting fire resistant encasements around steel ducts is up to 10m wide in accordance with the criteria of BS476: Part 24, exposed to external and internal fire. It is suitable for use as ventilation, kitchen extract and smoke exhaust ducting.

PROMATECT®-S self-supporting ducts can provide impact resistance in accordance with the criteria BS5669: Part 1 exposed to external and internal fire. Insulation will be as Duct type B (exposed to internal fire).

When measured on the section of duct on the unexposed surface in adjacent compartments, single layer of 6mm will give insulation of 30 and 15 minutes to Duct type A (exposed to external fire) and Duct type B (exposed to internal fire) respectively; single layer of 9.5mm will give insulation of 60 and 30 minutes to Duct type A (exposed to external fire) and Duct type B (exposed to internal fire) respectively.

For latest information of the Promat Asia Pacific organisation,
please refer to www.promat-ap.com

ASIA PACIFIC HEADQUARTERS

Promat International (Asia Pacific) Ltd.
Unit 19-02-01, Level 2 PNB Damansara
No.19 Lorong Dungun, Damansara Heights
50490 Kuala Lumpur
MALAYSIA
Tel: +60 (3) 2095 5111
Fax: +60 (3) 2095 6111
Email: info@promat-ap.com

AUSTRALIA

Promat Australia Pty. Ltd.
1 Scotland Road, Mile End South
Adelaide, SA 5031
Tel: 1800 PROMAT
Fax: +61 (8) 8352 1014
Email: mail@promat.com.au

New South Wales Office

Promat Australia Pty. Ltd.
Unit 1, 175 Briens Road
Northmead, NSW 2152
Tel: 1800 PROMAT
Fax: +61 (2) 9630 0258
Email: mail@promat.com.au

Victoria Office

Promat Australia Pty. Ltd.
3/273 Williamstown Road
Port Melbourne, VIC 3207
Tel: 1800 PROMAT
Fax: +61 (3) 9645 3844
Email: mail@promat.com.au

Western Australia Office

Promat Australia Pty. Ltd.
Locked Bag 8
Subiaco, WA 6904
Tel: 1800 PROMAT
Fax: 1800 33 45 98
Email: mail@promat.com.au

CHINA

Promat China Ltd.
Room 503, Block B, Qi Lin Plaza
13-35 Pan Fu Road
510180 Guangzhou
Tel: +86 (20) 8136 1167
Fax: +86 (20) 8136 1372
Email: info@promat.com.cn

Beijing Office

Promat North China
(Division of Promat China Ltd.)
Room 1507 Building 5, SOHO Xiandaicheng
No.88 Jianguo Road, Chaoyang District
100022 Beijing
Tel: +86 (10) 8589 1254
Fax: +86 (10) 8589 2904
Email: info@promat.com.cn

HONG KONG

Promat International (Asia Pacific) Ltd.
Room 1010, C.C. Wu Building
302-308 Hennessy Road
Wanchai
Tel: +852 2836 3692
Fax: +852 2834 4313
Email: apromath@promat.com.hk

INDIA

Promat International (Asia Pacific) Ltd.
(India Representative Office)
610-611, Ansal Imperial Tower
C-Block, Community Centre
Naraina Vihar, Naraina
110028 New Delhi
Tel: +91 (11) 2577 8413 (general)
+91 (99) 6705 0813 (west area)
+91 (99) 8994 0505 (south area)
Fax: +91 (11) 2577 8414
Email: info-india@promat-asia.com

MALAYSIA

Promat (Malaysia) Sdn. Bhd.
Unit 19-02-01, Level 2 PNB Damansara
No.19 Lorong Dungun, Damansara Heights
50490 Kuala Lumpur
Tel: +60 (3) 2095 8555
Fax: +60 (3) 2095 2111
Email: info@promat.com.my

SINGAPORE

Promat Building System Pte. Ltd.
10 Science Park Road, #03-14 The Alpha,
Singapore Science Park II
Singapore 117684
Tel: +65 6776 7635
Fax: +65 6776 7624
Email: info@promat.com.sg

VIETNAM

Promat International (Asia Pacific) Ltd.
(Vietnam Representative Office)
Room 606 Gay Viet Plaza
180-182 Ly Chinh Thang Street
Ward 9, District 3, Hochiminh City
Tel: +84 (8) 931 5964 (south area)
+84 (4) 565 8101 (north area)
Fax: +84 (8) 931 5964 (south area)
+84 (4) 565 8677 (north area)
Email: thai@promat-asia.com (south area)
trangoc@promat-asia.com (north area)

Your local Promat supplier

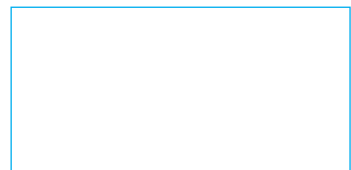

For Promat International groups worldwide: www.promat-international.com

1. This document is produced on the basis of information and experience available at the time of preparation. Promat is constantly reviewing and updating all of its test data and reserves the right to change products and specifications without notice.
2. Promat is not responsible if recipients of fire test reports, assessments or literature incorrectly interpret their contents and use products based on those interpretations.