

**Promat**



**PROMINA® 60**  
**Steel Stud Partition With Gypsum Plaster**



## Introduction

Partitions and external walls are used to separate buildings, enclose compartments and contain fire to provide a barrier to the passage of fire from one side or the other and are able to satisfy each of the relevant fire resistant criteria (integrity, insulation and, if the wall is loadbearing, load bearing capacity) from either side for the prescribed period. The application of partition and external wall systems using Promat boards covers both non loadbearing and loadbearing in commercial, industrial, institutional, residential and high-rise constructions, or in the restoration of existing buildings. Promat's internal partition systems require less material to achieve similar fire resistant level when compared to the industry average wallboard partition systems. The single layer board application leads to simplified construction methods over other equivalents hence increased productivity and reduced overall installation cost.

These partition and external wall systems have been developed by Promat International (Asia Pacific) Ltd. to satisfy standard requirements for intended applications. Such considerations include:

### Time & Cost Effectiveness

Single layer application reduces installation cost and time compared to traditional wallboard partitions.

### Slim Walls

Partitions can be as thin as 40mm.

### Lightweight

Lighter loads on structures compared to industry average wallboard partition systems for equivalent fire resistance.

### Thermal Resistance

Excellent thermal resistance performance.

### Impact Resistant

PROMATECT® 100 partition systems have been tested and assessed for impact and static loading to satisfy specification Cl.8 of the Building Code of Australia (BCA 2006). PROMATECT®-H partition systems have been tested for resistance to impact, stiffness and robustness in accordance with the criteria of BS5234: Part 2.

### Acoustic Performance

Tested and assessed to a range of standards, including ISO140-3 1995, ISO717-1 1996, AS1191 2002, AS/NZS 1276.1, BS5821 1984 and BS2750: Part 3: 1980, to meet the needs of industry. Please refer to [pages 6 and 7](#) for details.

### Fire Resistance Performance

Promat partitions and external wall systems have been extensively tested and assessed in accordance with BS476: Part 22 and AS1530: Part 4 to satisfy the integrity, insulation and where applicable loadbearing capacity (structural adequacy) criteria.

## General Design Considerations

The following points are some of the factors which should be considered when determining the correct specification to ensure a partition or external wall will provide the required design performance under both fire and ambient conditions. Further advice can be obtained from the local Promat office.

### 1. Studwork Design

The design of studwork should be adequate for the height of the partition. The studwork details given in the following specifications will be suitable up to the maximum heights stated. For greater heights the dimension of the framing members could change depending on the factors such as movement and deflection and local approvals. Larger or more frequent frame sections will often improve the fire and structural performance.

The studwork shall be appropriately designed for the applied loads, e.g. wind load, and where applicable structural load in the case of load bearing systems. The framing for the partition systems must be securely fixed back to a substrate that has an equal or greater fire performance than the designed partition. All fixings must be non-combustible and must be those listed in the approval documents. The design shall be in accordance with the relevant British, Australian and/or International Standards.

### 2. Non Loadbearing Partitions

Non loadbearing partitions and external wall systems using Promat boards can be generally divided into framing systems consisting of steel or timber studs and solid partitions. For steel stud systems, selection of suitable stud size shall be in accordance with the maximum partition height given in the stud selection tables. The partition systems in the following pages, where stated, are designed for lateral loads of up to 0.25kPa using the composite action of the frame and boarding.

### 3. Loadbearing Partitions

Loadbearing capacity of featured partition systems in this handbook are calculated in accordance with BS5950-8: 2003 and AS4600: 1996 for load cases defined by AS1170: 2002. The maximum load bearing capacity is given in kN for a given partition height taking into account the reduction in steel strength at elevated temperature.

Loads considered in this manual are for axial compression only. Wind and other loads have not been taken into consideration. For further information on these loads, please contact Promat Technical Department.

### 4. Deflection

Where differential movement is expected between the floor or beam above the construction, and/or the floor below, it is generally advisable to incorporate a deflection head track to ensure undue stress is not placed upon the partition. This also allows for the sagging and deflection a floor or structural steel beam will suffer under fire conditions. Even concrete floors will suffer considerable deflection under fire if exposed for any considerable duration.

Some form of movement joint is also required to allow for the expansion of the studs under fire conditions. A partition will also bow in its centre. As the wall bows, it will naturally get shorter. For this reason alone, use should be made of a top track with long side legs. This will allow the stud to bow and as a result drop down, without the studs dropping out of the head track.

### 5. Movement Joint

Movement stress from dimensional changes due to varying temperature or moisture conditions can cause cracking and other symptoms of distress in partitions. Other external forces such as impact or vibration can directly affect the structural movement of partitions. This movement can be controlled through a variety of design techniques such as introducing perimeter relief and slip connections to reduce the transfer of stress from the structure to other building sub-elements and/or through the use of expansion joints, control joints and construction joints.

In a partition, expansion joints are needed when the partition abuts a rigid mass. A vertical movement joint should be located at maximum 10m centres in long runs of partition. However, by introducing a control joint into a fire-rated partition, it does create an opening for flame and temperature transmission and therefore has to be properly treated with approved fire-stopping material.

Please refer to [page 12](#) for further details on movement joints.

*Continued on following page*

### General Design Considerations

*Continued from previous page*

#### 6. Caulking & Service Penetrations

To maintain the fire performance, and where applicable the acoustic performance of the partition system, gaps at perimeter must be appropriately filled with suitable caulking material. PROMASEAL® AN Acrylic Sealant or other tested fire and acoustic rated material of equivalent or better performance must be used.

Care needs to be taken in detailing a suitable fire-stopping system around any penetration of the partition by services to ensure a) the fire-stopping material remains in situ and b) fire and smoke do not penetrate the partition.

Allowance should be made for thermal movement of the services in both ambient and fire conditions to ensure loads are not applied to the partition. Some examples of service penetrations include electrical cables, conduits or wires, switches and power outlets, plastic and metal pipes, air-conditioning and ventilation ductwork.

#### 7. Fire Doors & Glazing

Tested or assessed door and/or glazed assemblies should always be used. All and any doors or glazed elements with a fire resistant wall should be shown, by fully compliant testing to the appropriate standard, to be capable of providing at least an equal fire performance to the wall itself. This means fire doors should be tested in lightweight partition systems, not just in masonry. In most cases additional framework will be required to prevent loads being applied to the partition. Careful detailing is needed around the perimeter of any door or glazed assembly. Further guidance on the detailing at fire doors and glazing can be obtained on [page 10](#).

#### 8. Partition Junction

Care must be taken to ensure that partition corner junctions and intersections are stable for both fire and ambient conditions. Framing at these locations has to be mechanically fastened together. Further guidance on the detailing at these junctions can be obtained on [pages 13 and 14](#).

### Steel Frame Components

#### Board Fixing

Promat boards may be installed horizontally or vertically.

For steel stud partition system, joints in the boards must be staggered between either side of the framing with all the joints located at a framing member. The boards may be fixed to the studs using No.8 Bugle head self drilling and self-tapping screws of a length appropriate for the board thickness. Needle point screws are normally used to fix boards to light gauge steel frames up to 0.8mm. Drill point screws are generally appropriate for heavy gauge steel frames from 0.8mm to 2.0mm.

For solid partition system, joints between the adjacent boards must be staggered by at least 300mm. First layer of the boards are to be fixed to the perimeter angle with 35mm long x No.8 self-drilling and self-tapping screws. The subsequent layer of the boards is to be stitched to the preceding layer with 40mm long x No.10 laminating screws, as well as fixing to the perimeter framing.

When a timber frame is used, Promat boards are fixed to the framework using No. 6 wood screws of a length appropriate for the board thickness at maximum 250mm centres, a minimum of 12mm from the board edge. Minimum edge distance to fasteners and the maximum spacing between screw must be maintained. Please refer to system detail for screws spacing requirements.

Internal and external corners may be set using a perforated metal corner bead fixed to the board linings at not more than 500mm centres.

#### Components Selection

Construction of Promat fire rated steel stud partitions can be achieved using Rondo stud and track components. Other steel components of equivalent performance can of course be used but it is the responsibility of the manufacturer of the component to substantiate equivalent performance with the recommended component.

#### Tracks At Deflection Head & Floor

The main function of the ceiling and floor tracks is to hold the studs in position until the board is fitted. They provide for a friction fit of the studs and also act as a slip joint to allow for any movement in the structure.

The track sections basically come in two profiles. A standard track has a nominal 32mm flange whilst the deflection head track has a nominal 50mm flange. However, head tracks with wider flange are available but they have to be specially designed for instances where clearance for expansion at the head track exceeds 20mm.

No clearance for expansion is applicable at the head track for a loadbearing partition.

Track sections should be fixed at maximum 600mm intervals to the supporting structure. Fixings should be located not more than 100mm from either end of the track section.

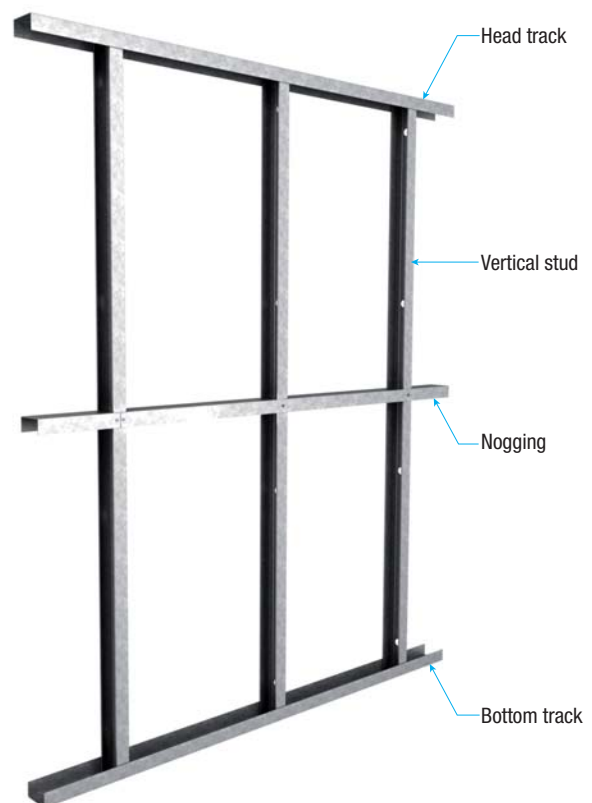

### Steel Frame Components

#### Steel Studs

The recommended Rondo studs come in 0.50mm, 0.55mm, 0.75mm and 1.15mm. The 0.50mm to 0.75mm studs have a standard 25mm bell-mouthed service holes for electrical cabling. For the 1.15mm stud, punched round holes are processed at designated centres along the stud.

Spliced extensions are possible in situations where the overall height of the partition is more than the stud length. The 0.50mm to 0.75mm studs may be boxed and the 1.15mm studs may be spliced back to back.

For greater rigidity at fire resistant glazing and door openings, and also at locations where extra load carrying capacity is required, studs of 0.50mm to 0.75mm may be boxed and studs of 1.15mm may be fixed back to back. See below guide on spliced studs and stiffening framing.



#### Guide to fixing spliced studs for partition heights up to 7000mm

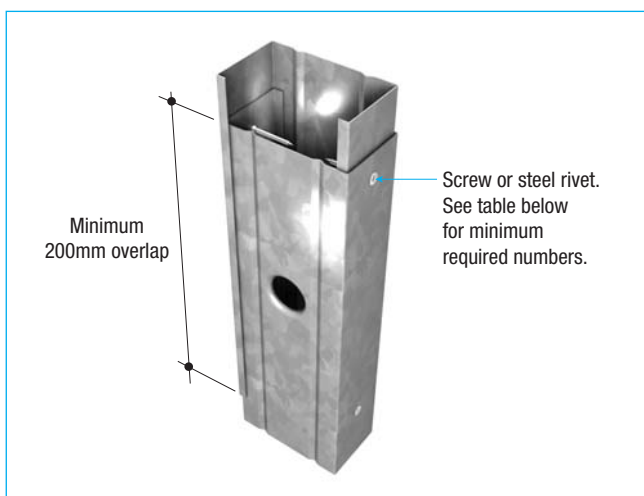

#### 1. 0.50/0.55/0.75mm Studs

Splice location in wall	Minimum required fasteners on both sides of studs over splice
Up to 10%	2 pieces
10% to 25%	3 pieces

NOTE: The splice location % refers to the height of the partition. For example, taking a partition 10,000mm high, a 10% splice location would be located within 1000mm of the top or bottom of the wall. A 25% splice location would be within 2000-5000mm of the top or bottom of a 10,000mm high wall.

- Splices should be alternated top & bottom of wall.
- Do not splice studs between 25% and 75% of wall height.
- Splicing of studs is recommended for non-loadbearing partitions only.
- Where splicing is not possible due to the height, use fully boxed sections.

#### Nogging Track

Noggings are necessary to provide bracing to the partition studs and preventing the studs from twisting when fitting the lining boards. The noggings are to be screwed, rivetted or crimped to both flanges of the studs. Continuous nogging tracks 0.55mm and 0.75mm are available from Rondo. This nogging track can be fitted to the stud framing in one length. Alternatively, individual noggings may be cut from the track. Noggings of 0.75mm can be used with 1.15mm studs.

#### Nogging track framing

Track to be fastened to substrate floor and ceiling with M6 anchor bolts 40mm long at maximum 600mm centres. Studs can be installed vertically at 600-610mm centres (distance depends on the size of the boards use). See details of **Bottom track fixing** at right and **Top track fixing** on following page.

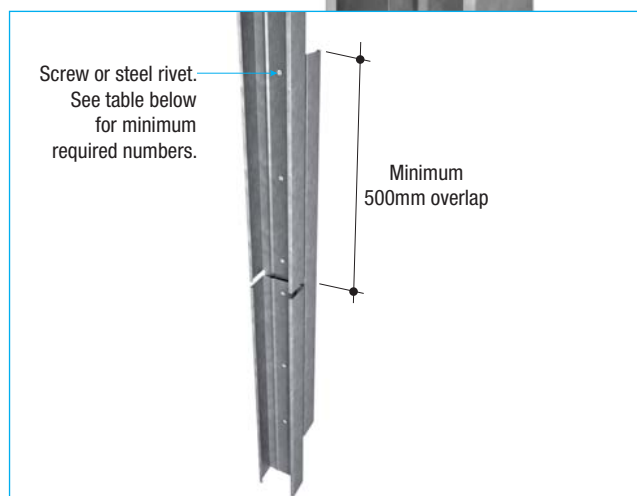

#### 2. 1.15mm Studs

Splice location in wall	Minimum required fasteners on both sides of studs over splice
Up to 10%	3 pieces
10% to 25%	5 pieces

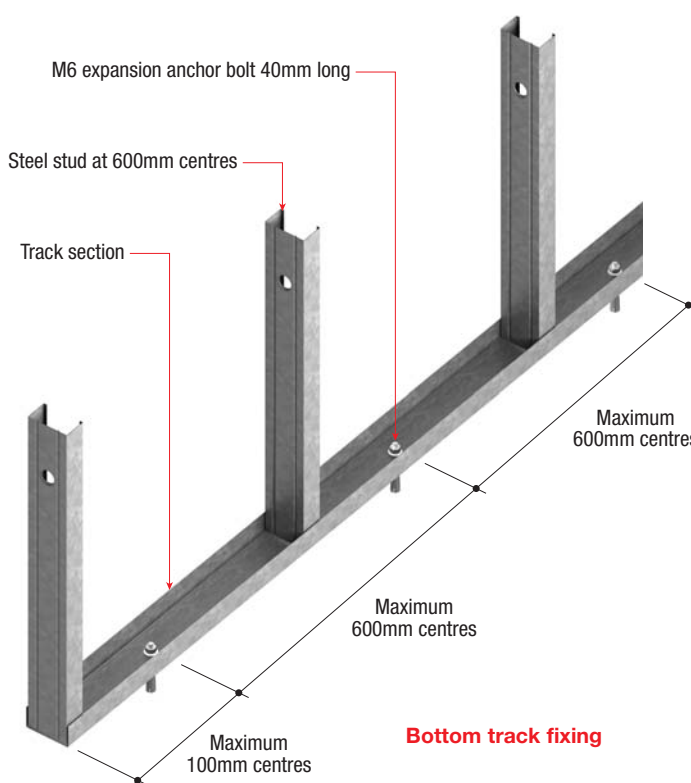

Continued on following page

### Steel Frame Components

Continued from previous page

#### Nogging track framing

Below are the options for different methods of providing noggings.

##### Steel stud as the horizontal track

- Studs to be cut to a short length and screwed in between each of the vertical studs.
- Cut the base of the track leaving two short studs either side. Insert between the vertical steel studs and fix through the studs into the vertical studs either side, using steel (not aluminium) rivets or screws.
- All horizontal joints of the boards will be fixed to the noggings.

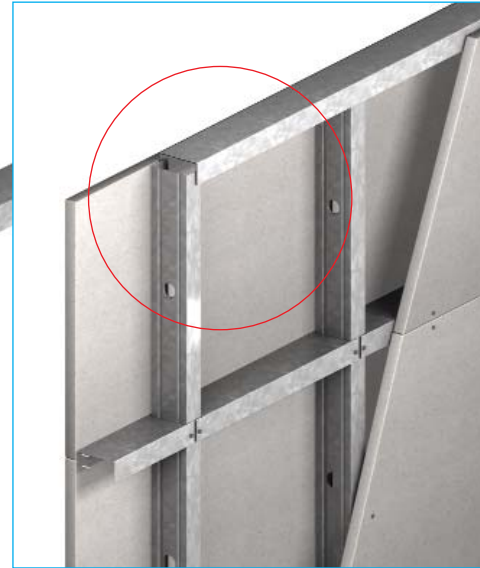
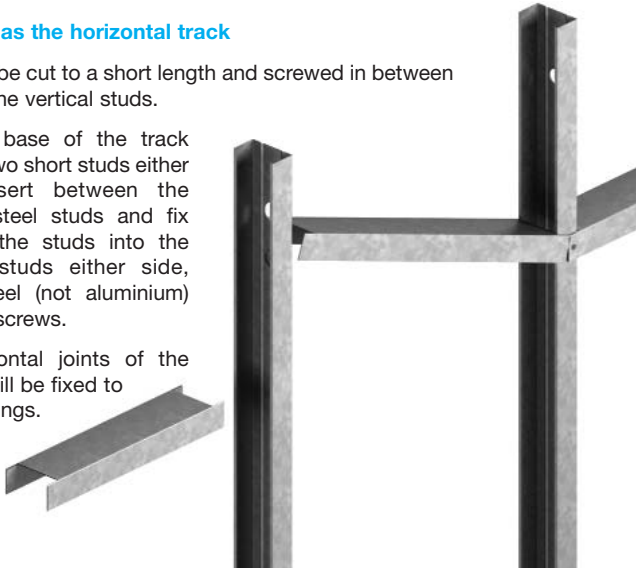

##### Steel channel as the horizontal noggings

- Steel channel to be cut in length and screw fixed to the both sides of the vertical studs.
- All horizontal joints of the boards will be fixed to the nogging.

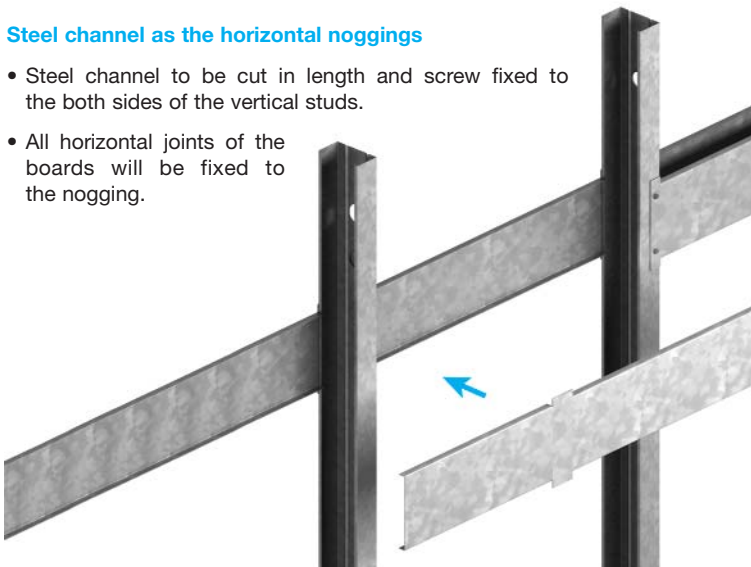

##### Board strips at the horizontal joints

- Cover fillets minimum 75mm wide cut from main lining boards. Fix board to board using stitching screws of a length appropriate to the board thickness, at nominal 200mm maximum centres.
- All horizontal joints of to the board strips.

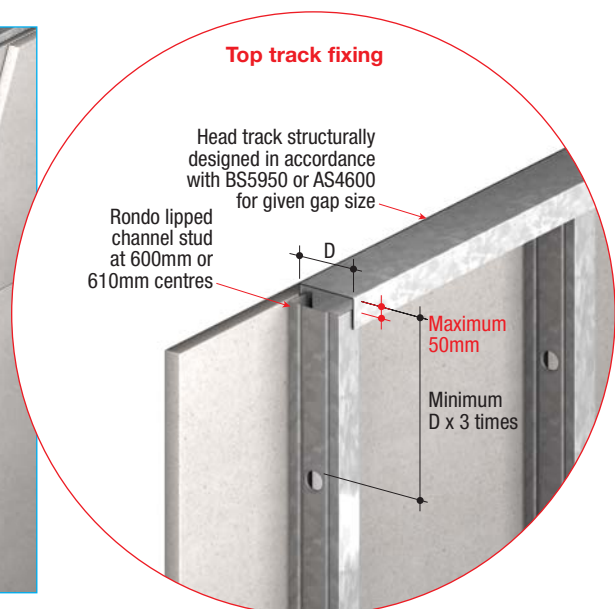

### Acoustics In Building

Sound is an energy generated by a source, transmitted through a medium and collected by a receiver. It can be pleasant to be heard, such as music and speeches etc, while some, such as scratching a glass surface with a sharp object, are irritating. This offensive sound is commonly termed noise. The acoustic design of buildings can be divided into two basic requirements, noise control and room acoustics.

Noise control relates to the quantity of sound with an objective to ensure the sound level does not adversely affect the comfort of building occupants. This involves control of sound produced in a room, such as telephones ringing, as well as limiting the noise entering from other rooms or outside the building. A common solution targeting this problem is the introduction of sound absorption systems.

Room acoustics relate to the quality of sound with an objective to enhance the quality of desired sound within a room. This involves factors such as speech intelligibility and perception of musical clarity. The most widely applied solution employed by building designers is the use of a sound insulating system.

A point worth noting is that although both noise control and room acoustics have independent objectives, they are however inter-related in practice. As this manual covers partition and ceiling systems, the following concentrates only on issues related to sound insulation which involves transmission loss (TL) of airborne sound.

### Sound Transmission & Classification

The sound transmission loss of a building element, such as a partition, is a measure of how much sound is reduced as it passes through the barrier, expressed in dB or decibels, the unit used to quantify sound. The generally accepted term for the single number ratings for sound transmission loss is the Sound Transmission Class or STC (ASTM E413). This is determined by comparing the TL value to the reference curve in ASTM E413. Generally the higher the STC value, the better the performance of the system. The following table provide a rough idea of what various STC levels mean in terms of privacy afforded.

STC	Privacy afforded
25	Normal speech easily understood
30	Normal speech audible, but unintelligible
35	Loud speech understood
40	Loud speech audible, but unintelligible
45	Loud speech barely audible
50	Shouting barely audible
55	Shouting not audible

Source: U.S. Dept of Commerce/National Bureau of Standards Handbook. "Quieting: A Practical Guide to Noise Control".

Another widely accepted equivalent term is the Weighted Sound Reduction Index or  $R_w$  (ISO 717: Part 1 or BS 5821: Part 1). It is determined in a similar manner but instead of TL values, an equivalent Sound Reduction Index ( $R$  or  $R_w$ ), is used.

Note should be taken that results obtained in STC and  $R_w$  may have a  $\pm 3$ dB deviation from one another.

Most building structures are not built like laboratories and it is very common that the sound insulation rating measured in ideal test conditions will not be achieved in a building. In order to meet the desired level of performance, building designers should therefore carefully consider the compatibility of the selected system with the supporting structure. Note that field performance is typically lower than laboratory performance by approximately 10%.

### General Design Considerations

With modern design concepts and technology in building construction, acoustic performance within buildings has become an important element for consideration by building designers. There are many factors involved in establishing an ideal noise level for any particular building space, part of which are as follows:

- To avoid fatigue induced by noise;
- To prevent distraction or disturbance;
- To maintain a good communication & listening environment.

Heavy walls such as concrete have good transmission loss. However, there are some drawbacks which limit its performance. Mass law dictates that a wall will increase its transmission loss by only 5dB for every doubling of mass. Therefore, a single 100mm thick concrete wall of 2300kg/m<sup>3</sup> density might have an STC 45 rating whereas a 200mm thick concrete wall would only achieve STC 50 for a doubling in mass. For most owners and builders, a wall of this size and weight is not desirable. Cost may more than double and the decibel-per-dollar achieved is clearly not acceptable. This limitation can be easily overcome by using a lightweight system, i.e. the partition system, where it is more practical to utilise principals such as air cavity, resilient mountings, sound-absorbing core materials or a combination of these principals without the large increase in mass required for solid walls.

Following are some common practices that are effective for noise control and room acoustics.

#### 1. Double-studding & Air Cavity

With typical drywall partitions, sound striking at the wall surface is transmitted through the first surface material into the wall cavity. It then strikes the opposite wall surface, causing it to vibrate and transmit the sound into the air of the adjoining room. This is termed airborne sound. When the sound strikes the wall at the stud, sound is transmitted direct through the stud and is termed structure borne sound.

The principal of double studding basically means separation of two panels of a drywall partition into a double-leaf wall, integrated with appropriate air spacing (cavity) between the leaves. The introduction of an air-space provides some form of separation or discontinuity between the two wall faces in a double-leaves wall.



As an example, a double stud partition creating an air cavity eliminates direct mechanical connection between the surfaces. The sound transmission is reduced by breaking the sound path. In addition, the air cavity provides vibration isolation between the two sides. Sound in one room striking the one side of the wall causes it to vibrate but because of the mechanical separation and the cushioning effect of the cavity, the vibration of the other side is greatly reduced.

#### 2. Sound-absorbing Core Material

Sound absorption is the effectiveness of a material at preventing the reflection of sound. Generally, the more sound absorption, the fewer echoes will exist. The sound-absorbing core used in the Promat partition designs can be mineral or rock wool, glass wool or polyester, depending upon fire resistance requirements.

These cores will further improve the sound isolation performance of the wall by absorbing sound energy in the cavity before the sound can set the opposite wall surface in motion. They will also provide some damping of the vibrating wall surface.

### General Design Considerations

#### 3. Treatment To Flanking Paths

When working with acoustically rated systems, it is critical that strict attention be paid to construction and detailing. The acoustic integrity of a system can be influenced by the combination of elements that make up the system. Single leaf and uninsulated systems are especially more dependent on high quality of installation. For example, if there is a gap of 5mm wide around the perimeter of an STC 45 rated wall of 3m x 3m, the actual performance would degrade to some, STC 30. Therefore to make acoustically rated partitions effective, they must be airtight. Any path for air also means there is a path for sound. In order to achieve the designed STC rating closely, the following factors must also be taken into account:

- Sound paths, e.g. windows, doors, floors and ceilings;
- Penetrations through walls, even above ceilings or below floorings, must be sealed;
- Stagger the joints between multiple layers of wall boards or ceiling linings;
- Do not use power points back to back on either side of a wall;
- Openings for return air in ceiling plenum systems must be strictly controlled.

#### 4. Wall & Floor Intersections

A good acoustical partition is only as good as its joint or intersection at wall and floor, like a chain and its weakest link. If this joint or intersection is not treated properly, the acoustical value may be lost. Many joint defects from flanking paths allow sound to travel via air gaps through the structure.

Acoustical sealants are the simplest means to provide a permanent air-tight seal. They are made from materials that are permanently elastic which will allow floor or wall materials to move, as they are prone to do because of expansion and contraction or outside forces such as structural movement. A permanent air-tight seal is the most effective way to maintain the acoustical integrity of the wall. Regardless of which system is employed, all openings, cracks and material joints should be made air-tight with a permanently elastic acoustical sealant.

### System Selection Guide

As sound insulation requirements may vary from country to country, the table below suggests acoustic values for some typical partition installations, unless otherwise specified by the architects. Please consult Promat for more information.

STC rating			Applications for separating
Minimum	Average	Luxury	
45dB	50dB	55dB	Bedroom to bedroom
50dB	55dB	60dB	Bedroom to living room
50dB	55dB	60dB	Bedroom to lobby
45dB	50dB	55dB	Office to office
40dB	45dB	50dB	Office to general area
45dB	50dB	55dB	Office to conference room
45dB	50dB	55dB	Office to washroom
40dB	45dB	50dB	Conference room to general area
40dB	45dB	50dB	Conference room to conference room
45dB	-	-	Classroom to classroom
55dB	-	-	Classroom to shop
45dB	-	-	Classroom to recreation area
60dB	-	-	Classroom to music room



Some sources of sound leakage

- 1** Air leaks through gaps or cracks
- 2** Doors
- 3** Light weight panels above doors
- 4** Electrical outlets and service pipes
- 5** Partition performance
- 6** Sound transmission via suspended ceilings or partitions
- 7** Common floor heating duct
- 8** Common ventilation system without sound absorbents treatment
- 9** Lightweight mullion or partition closer
- 10** Appliances

Fire attack from either side / Non loadbearing



Fire Rating	FRL	-/120/120
	STANDARD	BS476: Part 22: 1987 AS1530: Part 4: 2005
	APPROVAL	PSB G41751/TSM BRE CC89767B
Acoustic	# STC # R <sub>w</sub>	46dB 45dB
	STANDARD	ISO140: Part 3: 1996 ISO717: Part 1: 1996
	PREDICTED ASSESSMENT	Marshall Day 18th Oct 2006
Construction	MAXIMUM HEIGHT	7000mm
	MAXIMUM LENGTH	Unlimited
	PARTITION THICKNESS	Nominal 113mm
	PARTITION MASS*	From 25.80kg/m <sup>2</sup>

# Margin of error is generally within ±3dB.  
\* Details for walls above 3000mm high are available on request.

### TECHNICAL DATA

- 1 1 layer of PROMINA® 60 board 9mm thick
- 2 1 layer of gypsum wall board, 15mm thick.
- 3 Steel studs 65mm x 40mm x 0.8mm thick at maximum 610mm centres, see [Studs Table](#) on [page 15](#) for heights up to 7000mm.
- 4 Top and bottom tracks 65mm x 40mm x 0.8mm thick, fixed to substrate using 40mm x M6 masonry anchors at 500mm centres.
- 5 PROMASEAL® AN Acrylic Sealant, required only where gaps between board and substrate occur.
- 6 25mm self-tapping screws at nominal 300mm centres for the 1st layer gypsum wall board, and 32mm self-tapping screws at nominal 200mm centres for the 2nd layer PROMINA® 60.

### System Specification

Walls are to be constructed using PROMINA® 60 matrix engineered mineral boards all in accordance with the Architectural Specification in the manufacturer's handbook. Relevant constructions are to be selected according to the required FRL of (-/120/120). All printed installation details are to be followed to ensure approval to BS476: Part 22 and AS1530: Part 4. All work to be certified by installer in an approved manner.

Horizontal sheeting / Non loadbearing

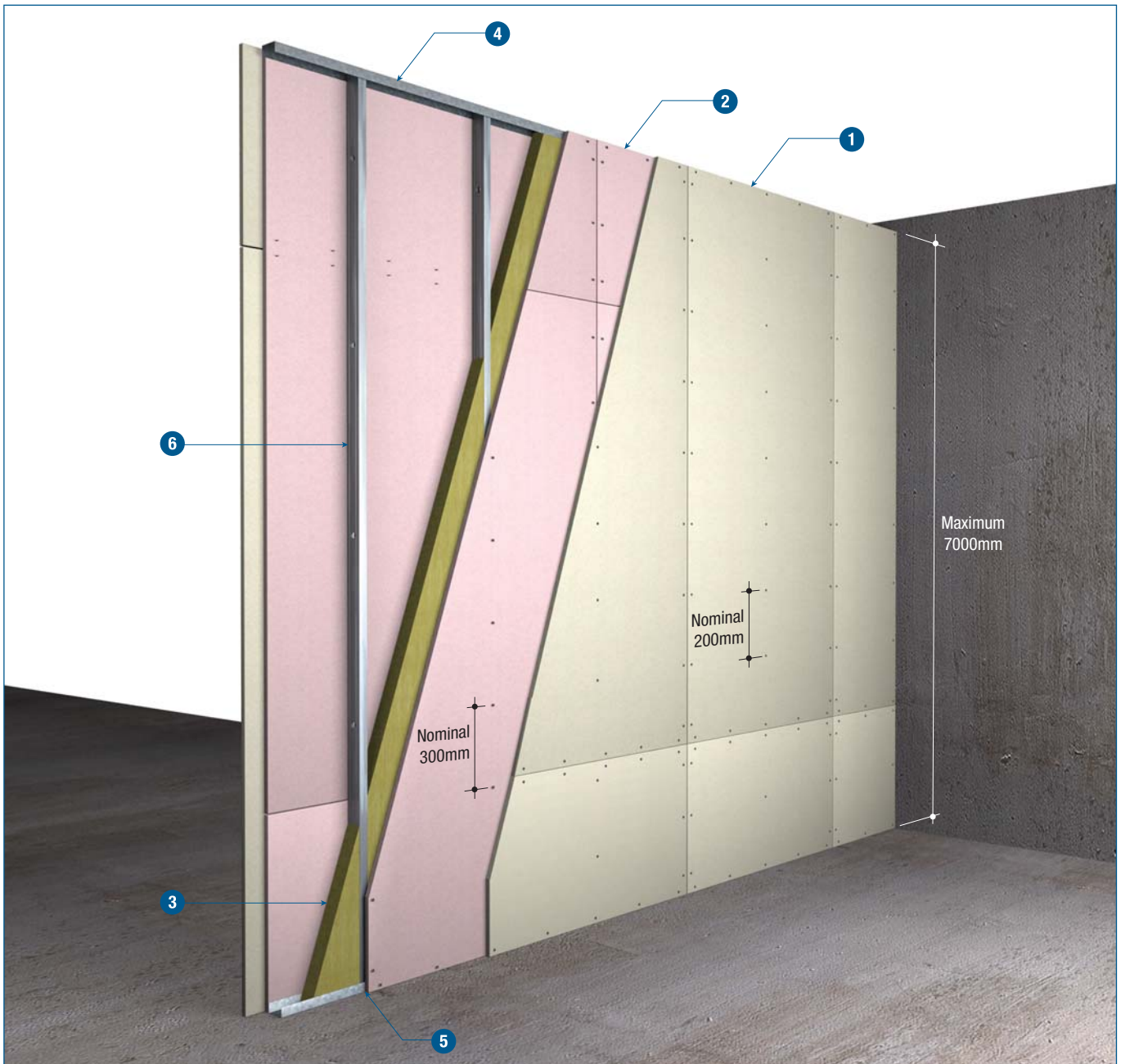

## TECHNICAL DATA

- 1 For FRL of -/120/120  
1 layer of PROMINA® 60 board, 9mm thick at each side of wall.
  - 2 1 layer of gypsum wall board, 15mm thick at each side of wall. All joints between layers staggered minimum 600mm.
  - 3 1 layer of mineral wool if required to improve acoustic performance (optional thermal insulation available on request)
  - 4 Allow appropriate clearance at top track, no clearance at top track for loadbearing partition. See [Studs Table](#) on [page 8](#).
  - 5 Caulk all perimeter gaps with PROMASEAL® AN Acrylic Sealant to achieve stated fire and/or acoustic performance
  - 6 Vertical studs 65mm x 38mm x 0.8mm thick at 610mm centres, see [Studs Table](#) on opposite page for heights up to 7000mm.
- See [page 11](#) for bottom and top track fixings; [pages 12 to 14](#) for details of wall head, wall base, wall movement joints and wall junction.

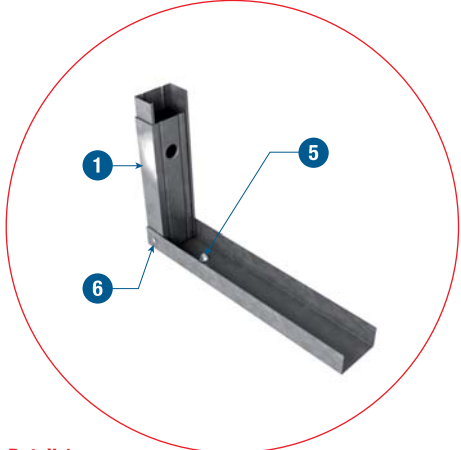
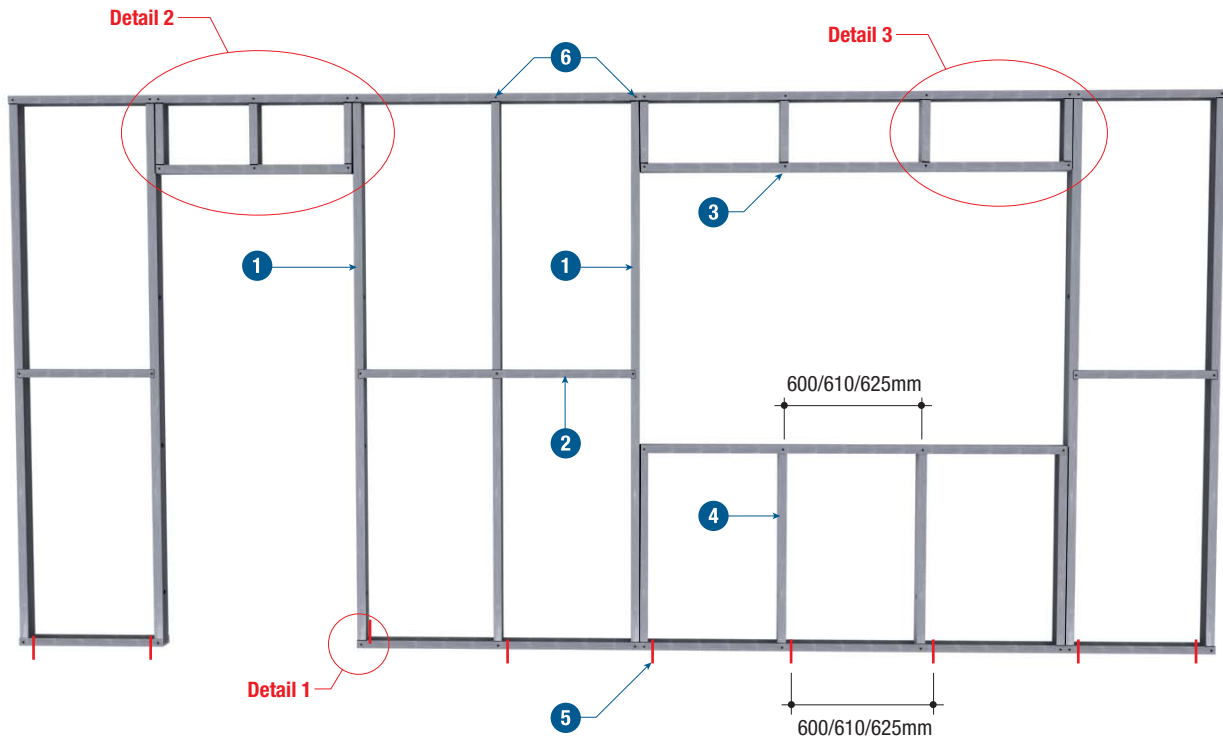

Detail 1

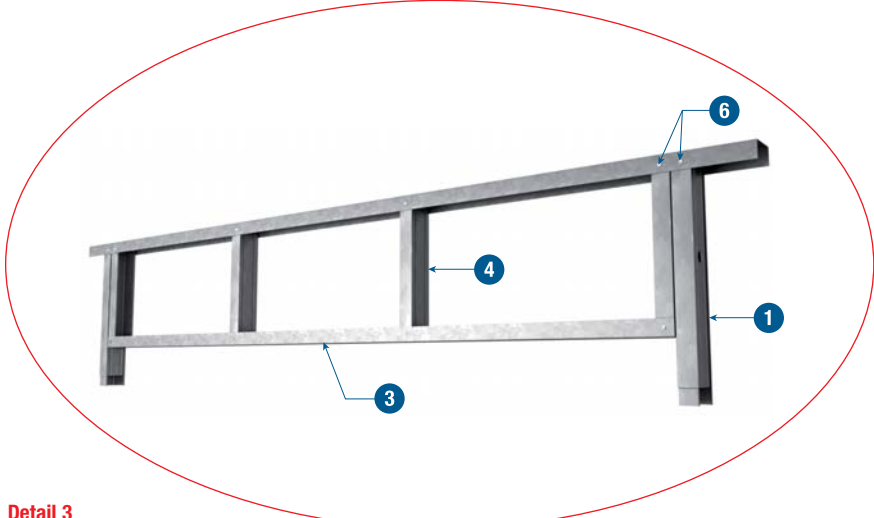

Detail 3

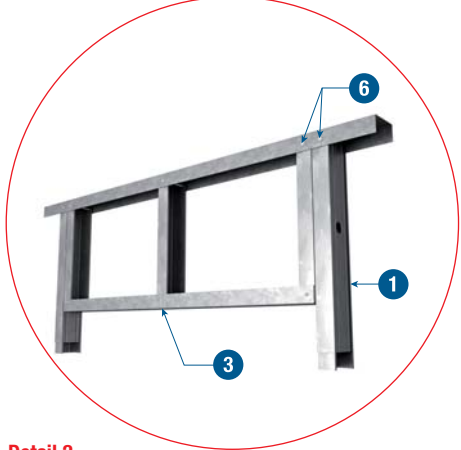

Detail 2

TECHNICAL DATA	
1	Boxed studs either side of openings, the studs need to be rigidly fixed top and bottom.
2	Horizontal noggings
3	Stud track
4	Maintain stud spacing above and below window or door openings
5	Expansion bolt at 600mm centres
6	No.8 wafer head screws 16mm long or 3mm steel pop rivets



### Steel stud frame for masonry wall

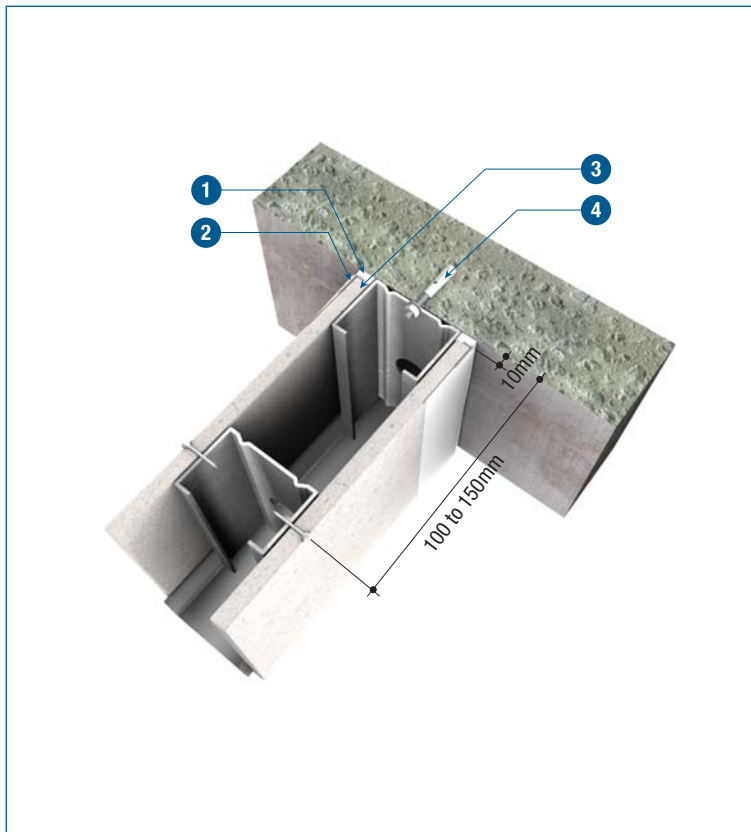

#### TECHNICAL DATA

- 1 Caulk all perimeter gaps with PROMASEAL® AN Acrylic Sealant to achieve stated fire and/or acoustic performance
- 2 RONDO stopping bead or similar and set over
- 3 Boards situated within profile therefore no fixing of board to wall stud required
- 4 M6 expansion bolt 40mm long at 600mm centres

### Steel stud frame

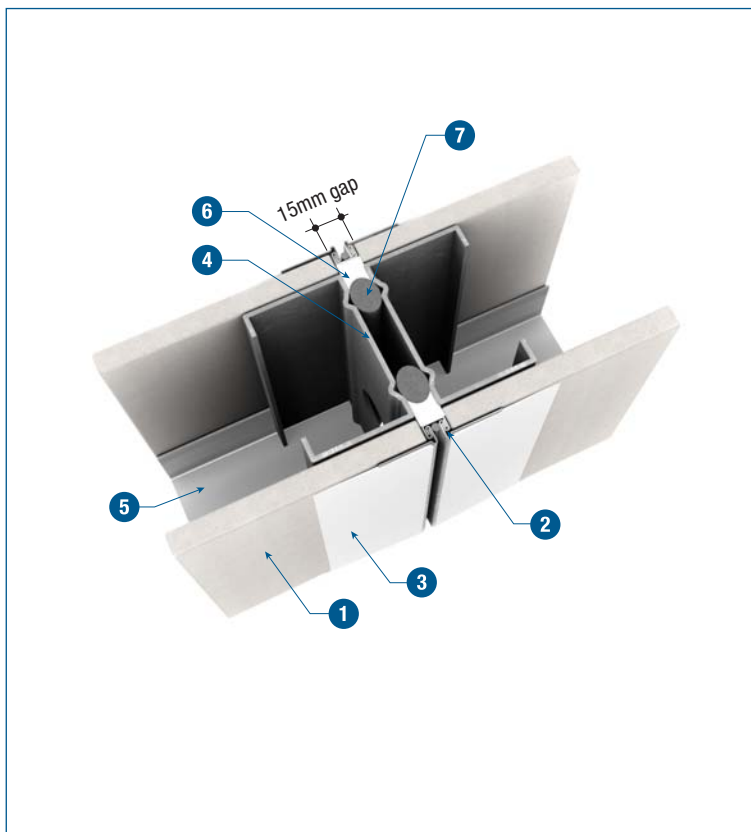

#### TECHNICAL DATA

- 1 PROMINA® 60 board
- 2 RONDO P35 control joint or similar
- 3 Flush joints
- 4 Studs at either side of control joint position
- 5 Track discontinuous at control joint
- 6 PROMASEAL® AN Acrylic Sealant (depth equal to board thickness) to achieve stated fire and acoustic performance
- 7 Backing rod non fire rated 22mm diameter

### Corner

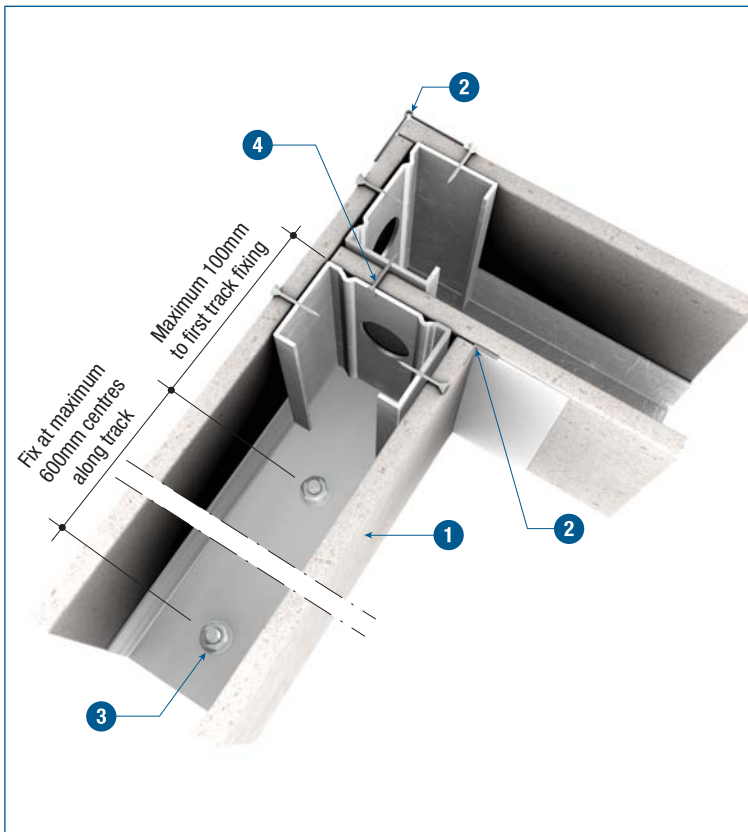

#### TECHNICAL DATA

- 1 PROMINA® 60 board
- 2 Set corner with tape and jointing compound
- 3 40mm x M6 expansion bolts at 600mm centres
- 4 Screw studs together at maximum 600mm vertical centres

### Intersection

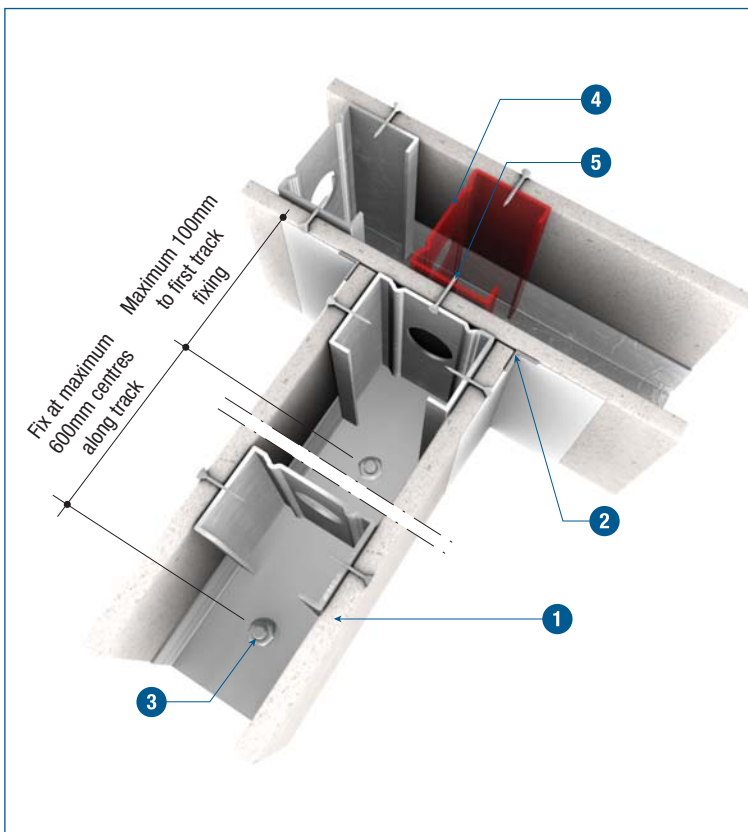

#### TECHNICAL DATA

- 1 PROMINA® 60 board
- 2 Set corner with tape and jointing compound
- 3 40mm x M6 expansion bolts at 600mm centres
- 4 Additional stud at wall intersection
- 5 Screw studs together at maximum 600mm vertical centres

### Wall end

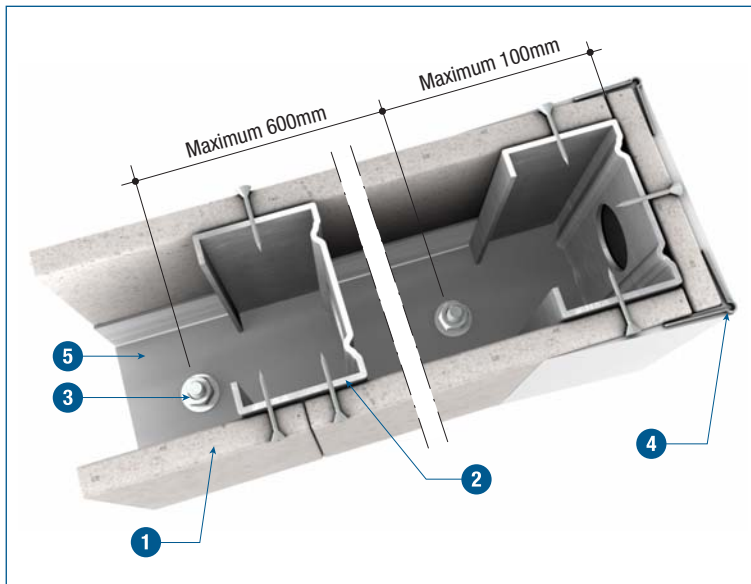

#### TECHNICAL DATA

- 1 PROMINA® 60 board
- 2 Stud
- 3 40mm x M6 expansion bolts at 600mm centres
- 4 Set corner with tape and jointing compound
- 5 Floor track

### Masonry wall intersection

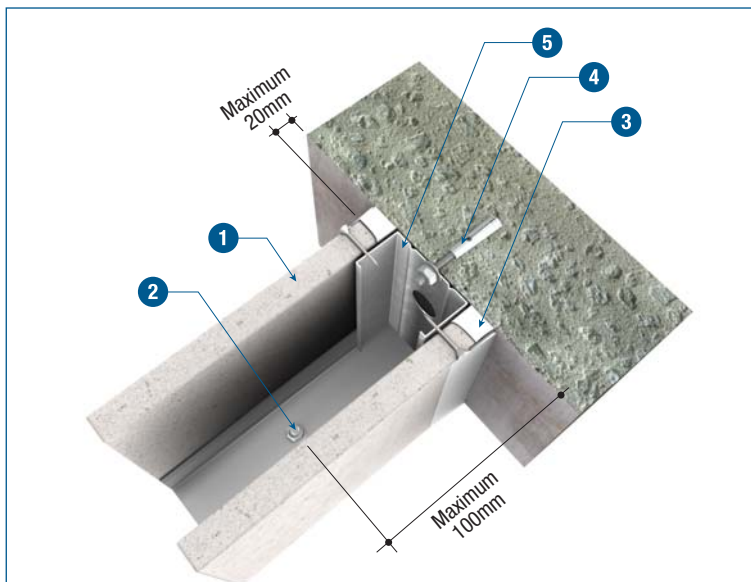

#### TECHNICAL DATA

- 1 PROMINA® 60 board
- 2 40mm x M6 expansion bolts at 600mm centres
- 3 Caulk all perimeter gaps with PROMASEAL® AN Acrylic Sealant to achieve stated fire and/or acoustic performance
- 4 Fix end stud to masonry at maximum 500mm vertical centres
- 5 Wall stud

### Angled wall intersection

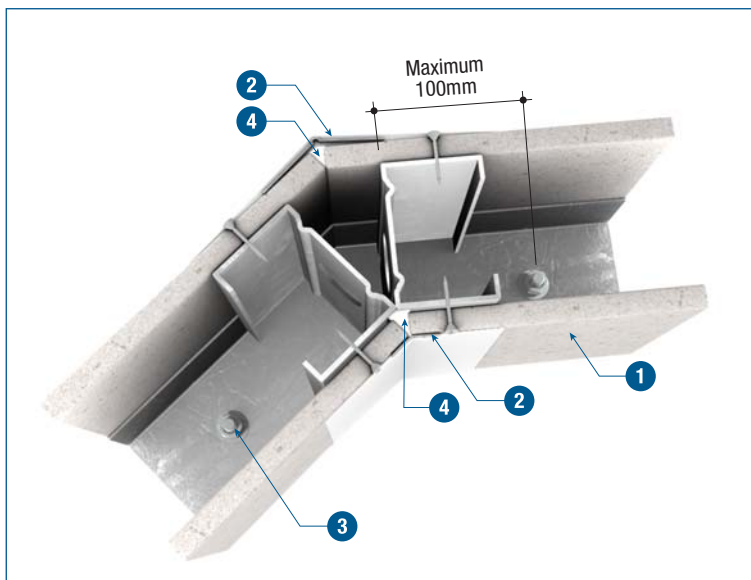

#### TECHNICAL DATA

- 1 PROMINA® 60 board
- 2 Set corner with tape and jointing compound
- 3 40mm x M6 expansion bolts at 600mm centres
- 4 PROMASEAL® AN Acrylic Sealant to maintain fire and acoustic performance

## Architectural Specification

The following are standard Architectural Specifications for internal partition systems using PROMINA® 60. The designer must determine the suitability of the design to the application and requirements before undertaking or constructing any works relating to the specifications and where in doubt should obtain the advice of a suitably qualified engineer.

### Fire Attack From Either Side / Non Loadbearing

Up to 120 minutes of fire rating, integrity and insulation in accordance with the criteria of [BS476: Part 22: 1987](#) and [AS1530: Part 4: 2005](#).

### Acoustic Performance

The partition system shall have a Weighted Sound Reduction Index of at least  $R_w$  45.

### Supporting Structure

Care should be taken that any structural element that the partition system is supported from, e.g. concrete/brick wall or slab, has at least an equivalent fire resistance.

### Lining Boards

Single layer of 15mm gypsum wall board.

Single layer of 9mm PROMINA® 60 matrix engineered mineral boards as manufactured by Promat International (Asia Pacific) Ltd. All joints to be coincident with PROMATECT®-H board strip. Standard board dimensions 1220mm x 2440mm x 9mm.

### Fixing

Galvanised steel frame made of ceiling and floor tracks will be secured to the floor, ceiling and walls with 40mm x M6 masonry anchors at 500mm centres. Vertical steel studs are then friction fitted into the tracks at 610mm maximum centres for boards to be installed vertically.

#### Studs Table

Partitions lined with 9mm PROMINA® 60 (studs at 610mm centres).

Maximum partition height	Stud depth	Minimum stud thickness	Maximum partition thickness	Top track	Clearance at top track
3000mm	65mm	0.8mm	113mm	65mm x 40mm x 0.8mm	18mm
3500mm	65mm	0.8mm	113mm	65mm x 40mm x 0.8mm	21mm
4000mm	65mm	0.8mm	113mm	65mm x 40mm x 0.8mm	24mm
5000mm	65mm	1.0mm	113mm	65mm x 45mm x 1.0mm	30mm
6000mm	65mm	1.0mm	113mm	65mm x 50mm x 1.0mm	36mm
7000mm	65mm	1.0mm	113mm	65mm x 55mm x 1.0mm	42mm

25mm self-tapping screws at nominal 300mm centres for the first layer gypsum wall board, and 32mm self-tapping screws at nominal 200mm centres for the second layer PROMINA® 60 board.

### Tests & Standards

The complete system along with the material and framing is tested in accordance with BS476: Part 22: 1987. The partition system should meet the requirements as specified under Clause 5.

### Jointing

Plain butt joints between machined edges of boards. <sup>(1)</sup>

Joints filled in preparation for painting. <sup>(2)</sup>

Joints filled and taped in preparation for decoration. <sup>(3)</sup>

### Follow-on Trades

Surface of boards to be prepared for painting/plastering/tiling<sup>(4)</sup> in accordance with manufacturer's recommendations.

#### NOTES:

- <sup>(1), (2), (3), (4)</sup> delete as appropriate.
- Perimeter gaps will be filled with fire resistant PROMASEAL® AN Acrylic Sealant.

For latest information of the Promat Asia Pacific organisation,  
please refer to [www.promat-ap.com](http://www.promat-ap.com)

## ASIA PACIFIC HEADQUARTERS

**Promat International (Asia Pacific) Ltd.**  
Unit 19-02-01, Level 2 PNB Damansara  
No.19 Lorong Dungun, Damansara Heights  
50490 Kuala Lumpur  
MALAYSIA  
Tel: +60 (3) 2095 5111  
Fax: +60 (3) 2095 6111  
Email: [info@promat-ap.com](mailto:info@promat-ap.com)

## AUSTRALIA

**Promat Australia Pty. Ltd.**  
1 Scotland Road, Mile End South  
Adelaide, SA 5031  
Tel: 1800 PROMAT  
Fax: +61 (8) 8352 1014  
Email: [mail@promat.com.au](mailto:mail@promat.com.au)

**New South Wales Office**  
**Promat Australia Pty. Ltd.**  
Unit 1, 175 Briens Road  
Northmead, NSW 2152  
Tel: 1800 PROMAT  
Fax: +61 (2) 9630 0258  
Email: [mail@promat.com.au](mailto:mail@promat.com.au)

**Victoria Office**  
**Promat Australia Pty. Ltd.**  
3/273 Williamstown Road  
Port Melbourne, VIC 3207  
Tel: 1800 PROMAT  
Fax: +61 (3) 9645 3844  
Email: [mail@promat.com.au](mailto:mail@promat.com.au)

**Western Australia Office**  
**Promat Australia Pty. Ltd.**  
Locked Bag 8  
Subiaco, WA 6904  
Tel: 1800 PROMAT  
Fax: 1800 33 45 98  
Email: [mail@promat.com.au](mailto:mail@promat.com.au)

## CHINA

**Promat China Ltd.**  
Room 503, Block B, Qi Lin Plaza  
13-35 Pan Fu Road  
510180 Guangzhou  
Tel: +86 (20) 8136 1167  
Fax: +86 (20) 8136 1372  
Email: [info@promat.com.cn](mailto:info@promat.com.cn)

**Beijing Office**  
**Promat North China**  
(Division of Promat China Ltd.)  
Room 1507 Building 5, SOHO Xiandaicheng  
No.88 Jianguo Road, Chaoyang District  
100022 Beijing  
Tel: +86 (10) 8589 1254  
Fax: +86 (10) 8589 2904  
Email: [info@promat.com.cn](mailto:info@promat.com.cn)

## HONG KONG

**Promat International (Asia Pacific) Ltd.**  
Room 1010, C.C. Wu Building  
302-308 Hennessy Road  
Wanchai  
Tel: +852 2836 3692  
Fax: +852 2834 4313  
Email: [apromath@promat.com.hk](mailto:apromath@promat.com.hk)

## INDIA

**Promat International (Asia Pacific) Ltd.**  
(India Representative Office)  
610-611, Ansal Imperial Tower  
C-Block, Community Centre  
Naraina Vihar, Naraina  
110028 New Delhi  
Tel: +91 (11) 2577 8413 (general)  
+91 (99) 6705 0813 (west area)  
+91 (99) 8994 0505 (south area)  
Fax: +91 (11) 2577 8414  
Email: [info-india@promat-asia.com](mailto:info-india@promat-asia.com)

## MALAYSIA

**Promat (Malaysia) Sdn. Bhd.**  
Unit 19-02-01, Level 2 PNB Damansara  
No.19 Lorong Dungun, Damansara Heights  
50490 Kuala Lumpur  
Tel: +60 (3) 2095 8555  
Fax: +60 (3) 2095 2111  
Email: [info@promat.com.my](mailto:info@promat.com.my)

## SINGAPORE

**Promat Building System Pte. Ltd.**  
10 Science Park Road, #03-14 The Alpha,  
Singapore Science Park II  
Singapore 117684  
Tel: +65 6776 7635  
Fax: +65 6776 7624  
Email: [info@promat.com.sg](mailto:info@promat.com.sg)

## VIETNAM

**Promat International (Asia Pacific) Ltd.**  
(Vietnam Representative Office)  
Room 606 Giay Viet Plaza  
180-182 Ly Chinh Thang Street  
Ward 9, District 3, Hochiminh City  
Tel: +84 (8) 931 5964 (south area)  
+84 (4) 565 8101 (north area)  
Fax: +84 (8) 931 5964 (south area)  
+84 (4) 565 8677 (north area)  
Email: [thai@promat-asia.com](mailto:thai@promat-asia.com) (south area)  
[trangoc@promat-asia.com](mailto:trangoc@promat-asia.com) (north area)

## Your local Promat supplier

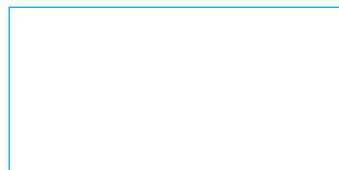

For Promat International groups worldwide: [www.promat-international.com](http://www.promat-international.com)

1. This document is produced on the basis of information and experience available at the time of preparation. Promat is constantly reviewing and updating all of its test data and reserves the right to change products and specifications without notice.
2. Promat is not responsible if recipients of fire test reports, assessments or literature incorrectly interpret their contents and use products based on those interpretations.